



Rapidly Attachable Fluid Transfer Interface



Enable In-Space Refueling For Your Spacecraft

The Rapidly Attachable Fluid Transfer Interface (RAFTI) is a passive fluid transfer interface that enables cooperative docking and refueling for spacecraft on-orbit. It consists of an octagonal grapple fixture and two valve cores. A single RAFTI interface supports the transfer of two independent fluids bidirectionally, for example propellant and pressurant. RAFTI also supports fill and drain functions for the propulsion system during ground operations.

Mass	1.1 kg
Max Operating Pressure, MEOP	400 psig (27.58 bar)
Proof Pressure	819 psig (56.47 bar)
Burst Pressure	1,336 psig (92.11 bar)
Maximum Allowable Flow Rate	500 mL/min (per valve core)
Valve Flow Coefficient (Cv)	> 0.06 (per valve core, bidirectional)
Cycle Life	100 cycles
Wetted Cleanliness	Level 100R1 per IEST-STD-CC1246E
Non-wetted Cleanliness	Level VC-0.5-1000 as defined within IEST-STD-CC1246E
Non-wetted Operational Temperature Range	-35 to 60 C
Non-wetted Survival Temperature Range	-35 to 80 C
Independent Inhibits	2 (mated and unmated)
Mated and Unmated Leakage	1E-6 sccs gHe
Environmental Standards	GSFC-STD-7000B General Environmental Verification Standard SpaceX Rideshare Users Guide
Compatible Media	<ul style="list-style-type: none"> Hydrazine per MIL-PRF-26536F Gaseous Helium per MIL-PRF-27407, Type I, Grades A or B Deionized Water per ASTM D1193, Type I Isopropyl Alcohol per TT-I-735, Grade A or better Gaseous Nitrogen of at least A-A-59503 Grade A or equivalent Additional media may be compatible. See wetted materials list.
Wetted Materials List	STAINLESS STEEL 304L PER ASTM A276 NITRONIC 60 PER AMS 5848 17-7 PER AMS 5678 Parker Compound E0540-80 (EPDM PER ASTM D2000)

Benefits

- Allows your spacecraft to take advantage of prepared, cooperative docking and refueling.
- Compatible with most spacecraft designs.
- Supports satellite servicing operations.
- Available off-the-shelf with minimal lead times and order quantities.
- Supports a variety of use cases and mission profiles.

Request a Quote → bd@orbitfab.com

Features



- The RAFTI system integrates easily with existing spacecraft configurations.
- Design in compliance to:
 - AFSPCMAN91-710 Range Safety
 - AIAA S-080A and SMC-S-016
 - NASA-STDs: 5005, 5006, 5017, 5019, 5020
- Two inhibits against leaks on ground and on orbit.
- Accommodates translational and rotational docking misalignment across all axes.
- Alignment markers improve docking performance and reduce complexity of proximity operations.

Dimensions [inches]

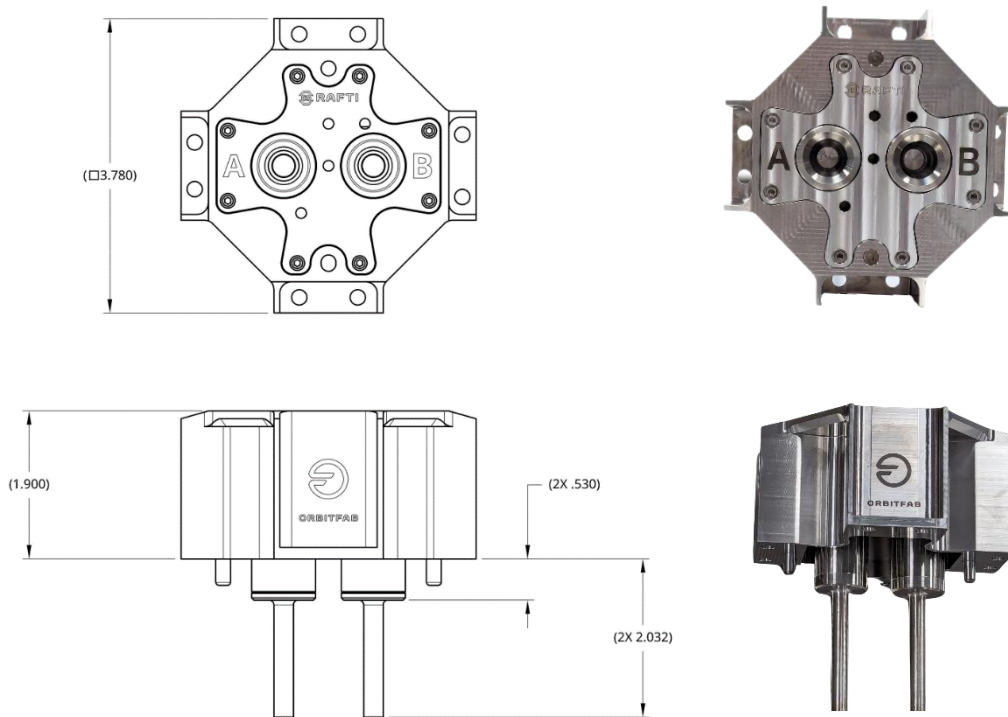

Integration

- Compatible with all major propulsion feed system types (e.g. blow-down, pressure regulated, pump driven, etc.)
- Spacecraft Interior: weld tube stubs at end of valve cores to propulsion system plumbing lines.
- Spacecraft Exterior: attach to external spacecraft plate with 4 flange mounts.

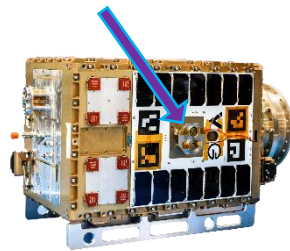

Ground Fueling

- Use RAFTI for Ground Fueling operations in place of a traditional fill and drain valve.
- Enabled by the RAFTI Ground Coupling (RGC) also offered by Orbit Fab.
- Fully range safety compliant for launch site fueling operations.

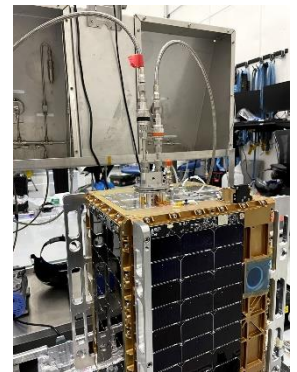

Request a Quote → bd@orbitfab.com